

---

**FOURTH JUDICIAL DISTRICT  
DEPARTMENT OF CORRECTIONAL SERVICES**

**Residential Correctional Facility (RCF)**

**900 9<sup>th</sup> Avenue**

**Council Bluffs, IA 51501**

**(712) 325-0364**

**Residential Treatment Center (RTC)**

**1102 9<sup>th</sup> Avenue**

**Council Bluffs, IA 51501**

**(712) 323-7687**

---

**MISSION**

The mission of the Fourth Judicial District Department of Correctional Services is to advance successful offender reentry to protect the public, staff and offenders from victimization.

**RESIDENTIAL CORRECTIONAL FACILITY / RESIDENTIAL TREATMENT CENTER  
 RULEBOOK  
 TABLE OF CONTENTS**

Orientation .....	1
Safety Information.....	1
Prison Rape Elimination Act (PREA) / Reporting / Advocacy.....	1-2
House Rules .....	2
Conducting Business at the Control Desk .....	2
Personal Accountability .....	2
Curfew Schedule .....	2
Living Quarters and Inspections .....	2-3
Wall and Foot Lockers.....	3
Facility Property.....	3
Offender Property .....	3-4
Laundry / Hygiene .....	4
Financial Obligations / Budgets .....	5
Fraternization .....	5
Yard Rules .....	5-6
Substance Abuse Monitoring .....	6
Food Service / Vending .....	6
Cleaning .....	6
Medication / Medication Line .....	7
Entryway Lockers .....	7-8
Cell Phones .....	8
Motor Vehicle Operations / Bikes .....	8-9
Employment .....	9
Job Seeking Form & Rules / Job Verification Process .....	9-10
Work Day & Work Hours.....	10
Missing Work Due to Illness / Change in Job Status.....	10
Temporary Employment / Temporary Agencies .....	10
Religious Services .....	10
Visitation .....	11-12
Pleasure Furloughs.....	12-13
Eligibility, Address Approval, Submitting a Furlough Request, Furlough Order & Regulations .	12-13
Medical Furlough Regulations .....	13
Passes .....	13
Gas Station .....	13
Check Cashing .....	13
Health Club .....	13-14
Religious .....	14
Restaurant .....	14
Grooming (Hair/Nails) .....	14
Shopping .....	14-15
Privileged Communication / Courts / Law Library .....	15
Correspondence .....	15-16
Grievances.....	16
Leisure Activities .....	16
Community Agency Referrals.....	16-17
Disciplinary Procedures .....	17
Disciplinary & Graduated Sanctions .....	17-18
Disciplinary Restriction Guidelines / Room & Facility Restriction.....	18
Rule Violations .....	18-22
Appeals .....	22-23
RCF Floor Plan .....	24
RTC Floor Plan .....	25

The following pages contain information regarding facility operations and your responsibilities, rights and privileges as an offender of a residential correctional facility. You are encouraged to review this rule book in order to understand what is expected of you. You will be held accountable for knowing and following the rules.

## ORIENTATION

The purpose of orientation is to provide you with a general overview of the Residential Correctional Facilities (RCF/RTC) and ensure you understand the conditions and expectations of the residential program. You will attend orientation within five (5) working days of your admission into the facility. Interpreters are available as needed. Individual case plan discussions occur with your assigned Probation/Parole Officer.

## SAFETY INFORMATION

**Evacuation:** You shall immediately report any fire or suspicion of fire to staff. You shall familiarize yourself with the evacuation plan and locations of fire extinguishers and fire exits in the building.



Activation of the fire alarm shall notify offenders, staff and visitors of a fire, fire drill or any other emergency necessitating the evacuation of the facility. Offenders, staff and visitors shall proceed to the nearest fire exit as designated on the evacuation plans posted throughout the facility.

After exiting the building at the RCF, all occupants shall proceed to the basketball court north of the building. At the RTC, all occupants shall proceed to the vacant lot east of the building.



**Tornado Watch** – Occurs when conditions are favorable for tornado development.

**Tornado Warning** – Occurs when a tornado has been sighted or indicated by Doppler radar; take cover immediately.

- RCF occupants shall proceed to the long hallway in the men’s wing.
- RTC occupants shall proceed to the staff break room.



**First Aid:** You are to immediately report to staff when first aid treatment or other medical care is needed.

**Medical Care:** Medical services are provided in the local community at the expense of the offender.

## PRISON RAPE ELIMINATION ACT

Fourth Judicial District Department of Correctional Services’ policy prohibits any activity associated with or that promotes acts of sexual misconduct, including sexual harassment between offenders and offenders, offenders and staff and staff and offenders. In this definition, “staff” includes: contractors, representatives or volunteers of the department. An “offender” means someone incarcerated in a correctional facility or under supervision in the community.

**There is zero tolerance for sexual violence.** Immediately report any incidents of sexual harassment or violence to staff. You have the right to be free from sexual abuse and sexual harassment and to be free from retaliation for reporting such incidents. The department will immediately investigate all reports of sexual harassment and sexual violence.

Offenders will be subject to formal disciplinary sanctions following an administrative finding that the offender engaged in offender-on-offender sexual abuse or following a criminal finding of guilt for offender-on-offender sexual abuse.

### **Reporting / Victim Advocacy Resources**

Local 24-hour Sexual Assault Program and Victim Advocates	1-888-612-0266
Iowa DOC Victim & Restorative Justice Program	1-800-778-1182
Iowa Crime Victim Assistance Division	1-800-373-5044
PREA Retaliation Monitor	712-396-2244

### **External Agency To Report To:**

Ombudsman’s Office , Ola Babcock Bldg, 1112 E. Grand Ave., Des Moines, IA 50319	1-888-426-6283
Iowa Coalition Against Sexual Assault, 3030 Merle Hay Road, Des Moines, IA 50310	

## **HOUSE RULES**

All Fourth Judicial District Department of Correctional Services buildings and grounds are smoke-free, except for designated areas. Therefore, tobacco, tobacco based products, imitation tobacco products, lighters, matches, igniters, vaping products, etc. and all other flammables are not allowed to be used unless in the designated areas.

### **Conducting Business at the Control Desk**

- RCF – You shall conduct your business in an orderly manner at the front or side window of the Control Desk.
- RTC – You shall conduct your business in an orderly manner in front of the Control Desk.
- Kiosks are available at both facilities to communicate with staff members.
- **When signing out, you will need to provide Control Desk staff with the following:**
  - Your ICON number
  - Purpose and exact location(s) you are going to (employment, treatment, furlough, etc.)
  - Mode of travel (walk, bike, bus, vehicle – only with approved transportation agreement, etc.)
  - Work hours / Appointment times / Return time to facility
  - Any other relevant information / special instructions

### **Personal Accountability**

- You are not allowed to leave the facility without prior permission from staff and completing the sign-out process.
- You are to conduct yourself appropriately. Physical violence, threats of physical violence and/or intimidating behavior against any other offender(s) or staff member(s) will not be tolerated. This includes:
  - Horseplay and such behavior as pushing, touching, striking, whether actual or jokingly, fighting, loud behavior, assaultiveness and disrespect toward others.
  - Profane language and gestures.
- You are not allowed access to staff offices, desks or phones. Do not enter the kitchen, administrative or PPO offices, closets, utility rooms or other restricted areas without staff permission.
- You shall be appropriately clothed by 9:00 a.m. while in the common areas of the facility and outdoors, wearing a shirt, pants and footwear. At no time shall undergarments be visible.
- When going to and from the showers and restrooms, you must wear pants/shorts, shirt or a robe and footwear.
- You are responsible for informing your assigned Probation/Parole Officer (PPO) regarding appointments with treatment providers and other community agencies.

**Curfew Schedule** Curfew hours are from 10:00 p.m. to 6:00 a.m. You are required to be:

- Inside the facility no later than 10:00 p.m.
- In your assigned room no later than 10:30 p.m. with bedroom lights turned off by 11:00 p.m. nightly.

If you return to the facility from work after curfew hours, you have one (1) hour before you are required to be in your bedroom.

### **Living Quarters and Inspections**

- You are only allowed to be in your assigned room and shall not be in any other offenders' rooms at any time.

- Food, candy and drinks are not allowed in bedrooms.
- The door window and vents may not be covered or blocked in any manner. You are prohibited from hanging any items from vents or fire safety devices.
- Do not open, tamper or remove bedroom windows or screens.
- Footwear shall be neatly arranged and stored under the lower bunk when not in use.
- All hygiene items are to be stored inside a locker.
- Clock radios and writing material shall be stored in an area near your bed in a neat and orderly manner. Nothing shall be placed on beds.
- Mesh type laundry bags shall be stored neatly in your living area.
- Pictures, stickers and drawings are not allowed on lockers, walls, doors or windows or window sills. Photographs of family may be displayed inside of lockers.
- Trash receptacles shall be emptied daily.
- The floor area must be swept and mopped daily and be free of clutter.
- **Bed / Bed Area**
  - Beds are to be made (including fitted sheet, flat sheet and blanket).
  - Blankets, sheets, towels or other clothing may not be hung on the sides of bed railings to obscure staff vision, or be placed over the bedroom windows.
  - Sleeping is only allowed in your assigned room and assigned bed. You are not permitted to sleep on a bare mattress.
- Turn off all lights and electronics when you leave your room.
- **Room inspections will be conducted by 11:00 a.m. daily.**

### **Wall and Foot Lockers**

All personal property, including hygiene items, shall be stored in your wall or foot locker. If items cannot fit into the wall locker or foot locker, it is your responsibility to remove the items from the facility or make arrangements to have them removed. **The facility will not store items.**

- Wall lockers must be secured with a combination lock when not in use.
  - Offenders are only allowed to use facility issued combination locks. These locks are rented from the facility and must be returned upon departure from the facility.
- Items of specific value, rings, watches and other expensive jewelry, should be secured in your assigned wall locker or removed from the facility as soon as possible.
- Foot lockers are to be stored under your bed.

### **FACILITY PROPERTY**

Abuse of facility property is not allowed and may result in the loss of privileges and/or reimbursement for damages.

- You shall refrain from actions that tend to have an abusive effect on the facility or any of its furnishings, i.e., feet on furniture, sitting on backs of chairs or on tables, leaning back in chairs, sitting on washers/dryers, etc.
- Repair costs shall be assessed against the offender causing the damage whether the damage was intentional or accidental.
- Graffiti and defacing/damaging state property is prohibited.
- Removing or defacing memos on the bulletin boards is prohibited.
- Furniture is not to be rearranged without staff approval.

### **OFFENDER PROPERTY**

You are responsible for bringing needed property to the facility upon admission. Deliveries of personal property may only be received at the facility between the hours of 8:00 a.m. and 4:30 p.m., Monday through Friday. Drop offs may be limited or denied at staff discretion. All personal property is the responsibility of the offender. The Department is not responsible for the replacement of lost, stolen or damaged property. All property will be searched by staff.

**In the event of an escape, your property will be disposed of immediately.**

The following is a list of approved personal property. Any item in your possession that is not on the approved list is considered contraband. Those items will be confiscated by staff and a disciplinary report may be written.

Pants (8 pairs)	Backpack
Shorts (5 pairs)	Alarm clock / Clock radio
Undergarments	Walkman / Cassettes / CDs
Shirts / Blouses (8)	MP3 (no video capability)
Hooded sweatshirts (3)	Shaving gel / cream (no aerosol cans)
Socks	Electric/Manual Razor with blades
Footwear (4 pairs)	Small, clip-on fan / lamp
Slippers (1 pair)	Hygiene products (alcohol-free items only)
Robe (1)	Hair dryer / Curling Iron
Pajamas (3)	Reading / writing materials
Coats (2)	Wallet / Purse
Dresses	Jewelry
Hats / Gloves / Scarves	Bicycle / Lock / Vehicle

*\*\* Personal property items shall not depict any gambling / gang affiliation / colors / symbols, have any alcohol or drug related references or obscene or racist symbols or pictures. Your clothing must be appropriate as determined by the Division Manager or Residential Supervisor (i.e. length of shorts).*

**Not Allowed**

- Items that contain alcohol (for example, mouthwash, perfume, cologne, hand sanitizer, hairspray, etc.). Alcohol-based hygiene items, such as shampoo, conditioner and shaving cream/gel may be permitted.
- Halter tops, tube tops, spaghetti straps or see-through shirts/blouses
- Items used for work, such as, tools, knives, razors, box cutters, etc.
- Electronic devices with internet capability
- External, portable speakers
- Extension cords, multi-plugins and adapters
- Hats, hoods, scarves and sunglasses shall not be worn in the building at any time.

Personal property that is considered to be contraband or excessive may be seized and disposed of by facility staff. Any personal property that is returned to you must be claimed and removed from the facility within a period of five (5) working days from the date of seizure. Any unclaimed personal property will be promptly disposed of.

Headphones must be used with music devices at all times.

**Laundry**

You must pay the linen fee upon arrival at the facility for issued linen. Each facility provides self-service coin-operated clothes washers and dryers. Laundry detergent is to be purchased at the facility. Laundry may be done while on pleasure furlough. Visitors cannot come to the facility to pick up your laundry.

You are responsible for laundering your bed linens and towels weekly.

Only mesh type laundry bags and plastic clothes hangers are permitted in the facility.

**Hygiene**

Personal hygiene shall be maintained daily. Hygiene items are provided for indigent offenders. Hygiene items include soap, shampoo, toothpaste, toothbrush, comb, brush, deodorant, razors and special items for female offenders.

## FINANCIAL OBLIGATIONS / BUDGETS

*Reference Iowa Administrative Code 904.905 and 905.12*

You must report and turn in all monies received for the purpose of budgeting. All monies shall be turned in to staff immediately upon arrival at the facility (cash, checks, pay cards, money orders, etc.). You are required to budget your money through Inmate Banking, accumulate substantial savings and demonstrate fiscal responsibility. You will be issued a receipt which will provide documentation that the earnings are in your account.

### Priority of Financial Obligations

1. Legal (**Section 904.905 & Chapter 910.5, Code of Iowa**)
  - a. Child support
  - b. Victim Restitution
  
2. Payment to the Fourth Judicial District Department of Correctional Services
  - a. Rent (assessed daily, beginning day of admission)
  - b. Treatment and treatment-related fees
  - c. One-time Linen and Padlock fee
  - d. Supervision fee
  - e. Savings in Inmate Banking
  - f. Interstate Transfer Fee (if applicable)

### Weekly Budget Form / Refund Check

Offender expenditures require staff approval and staff shall ensure only reasonable expenditures are authorized. If funds allow, offenders may be issued a weekly allowance check for personal expenses. All bills to be paid by the offender shall be mailed by the Department, unless other arrangements are approved in advance by the PPO. The bills to be paid must have the complete mailing address listed on the budget form. Approved budgeted items will be paid each Tuesday; holidays may delay payment until Wednesday. **Budget forms are due by 10:00 p.m. on Sunday.**

### Not Allowed

- Accruing Debt
- Credit/Debit cards
- Bank/Credit Union Accounts (Checking/Savings etc.)
- Betting, to include playing the Lottery and/or scratch cards
- Financial transactions between offenders, offenders and staff, offenders and vendors, etc. (Lending money to other offenders or borrowing money from other offenders)

When an offender goes on escape or is removed from the program, staff shall close the account after receiving and dispersing funds from the final paycheck.

## FRATERNIZATION

You are prohibited from associating with or having contact with residents of the opposite gender. This includes residents from the RCF, RTC and Transitional Living House.

## YARD RULES

**Outdoor recreation is a privilege and may be restricted for just cause. Outdoor recreation is limited to the north side of the RCF and the east side of the RTC. Yard time ends at 10:00 p.m.; you must be inside the building by 10:00 p.m.**

1. All Fourth Judicial District Department of Correctional Services buildings and designated grounds are smoke-free. Therefore, tobacco, tobacco based products, imitation tobacco products, lighters, matches, igniters, etc. and all other flammables are not allowed to be used in the buildings or on the non-designated property.

2. You shall be appropriately clothed while outdoors (shirts, pants/shorts and shoes).
3. Sun bathing is not permitted.
4. You shall stay away from the perimeter fence and stay out of all restricted areas – restricted areas include parking lots and entrance and exit doors.
5. Deposit trash in appropriate containers located in the yard; offenders who litter will be subject to disciplinary action.
6. Radios played in the yard shall be used with headphones and worn properly.
7. Recreation equipment is available and shall be stored when not in use.
8. Football is not allowed.

### **SUBSTANCE ABUSE MONITORING**

Use or possession of illegal drugs and/or alcohol is not permitted while you are a resident of a correctional facility. Urinalysis and breathalyzer testing is used to determine compliance with this rule and as such, you shall undergo periodic urinalysis and alco-sensor testing.

- You must provide a urine sample upon staff request within two (2) hours of notification. If the sample cannot be obtained immediately, you shall remain in the multi-purpose room under direct observation of staff. Failure to provide a testable sample within the two (2) hour timeframe may result in disciplinary action.
- It is against the rules to use any type of device or product that would alter the results of any substance abuse testing, including Ranitidine (Zantac), cough/cold medicine, etc.

### **FOOD SERVICE**

The facility provides three meals per day. Meals, candy, drinks, etc. are to be consumed in the multipurpose room only. Trays, dishes and utensils are not to be removed from the eating area.

**Meal times are:**

- Breakfast → 6:30 a.m. to 7:45 a.m.
- Lunch → 12:00 p.m. to 12:30 p.m.
- Dinner → 5:00 p.m. to 5:30 p.m.

Meals are not saved for offenders on pleasure furlough or day reporting. If you will be out of the facility during a meal time, for employment only, you may request a sack lunch when you sign out.

Regular coffee is permitted in the facility. Any coffee, or coffee type product, containing sugar is prohibited.

No outside food or drink may be brought in, unless medically required with a doctor's note. Special diets may be approved by the Division Manager/Designee if a medical, dental or religious need is documented.

Vending: All facility vending is at your own risk. The facility does not offer vending refunds.

### **CLEANING**

All in-house residents are responsible for participating in cleaning the facility nightly at 5:30 pm and 8:30 pm. All in-house residents will be required to gather in the multipurpose room to receive their cleaning assignment. Storage of cleaning supplies inside offender bedrooms or restrooms is prohibited.



## MEDICATION

Prescriptions are required to be filled by phone prior to leaving the facility to pick up the prescription.

You are required to turn in all prescription medication to the Control Desk prior to taking any of the medication. It is your responsibility to take your prescription medication as prescribed. Any prescription changes will need to be submitted to the facility in writing by your doctor.

At the RCF, you may have up to fifty (50) pills/tablets of over-the-counter pain reliever, in the original container. At the RTC, you are not allowed to have any over-the-counter pain reliever in your personal possession.

Only regular multi-vitamins may be taken while in the facility; no other types of vitamins, vitamin supplements or powders.

### Not Allowed to Possess or Use While Residing in the Facility

- Over-the-counter sleep aids
- Creatine supplements / Creatine powders
- Diet pills
- Any products containing hemp, cannabidiol oil (CBD) or tetrahydrocannabinol (THC) will not be allowed without a prescription

### Medication Line

Please see the posted schedule for medication times, which may vary, based on staff availability. You are required to take or obtain your medication at the posted medication times. Failure to request medications at medication time may be subject to disciplinary action.

- If you will be out of the facility during medication times, you may take the medication with you when you sign out. You will need to obtain a travel bottle from a pharmacy and request those medications at an earlier medication time. The travel bottle and any remaining medication shall be turned in to staff upon your return.

Unless otherwise specified in writing by a medical professional, medications will be passed at the following intervals:

- Twice daily meds: 10-12 hours between doses
- Three times daily meds: 6-8 hours between doses
- Four times daily meds: 4-6 hours between doses

“As Needed” medications will be taken at posted medication times, at the above intervals.

## ENTRYWAY LOCKERS

You may secure authorized tobacco products and one (1) cell phone in your assigned entryway locker. The facility is not responsible for any items stored in the entryway lockers. You are not allowed to share your combination with other residents or use other residents’ lockers. Sharing your combination with other residents will result in loss of your entryway locker privileges.

Items not allowed to be stored in entryway lockers include, but are not limited to:

- Items used for work, such as, tools, knives, razors, box cutters, etc. Arrangements must be made with your employer to leave these items at your job site.
- Car keys
- Butane lighters, loose tobacco, rolling papers, cigars, electronic cigarettes/vapes and chargers, “juices” and brown cigar-type cigarettes
- Food, drink or any other items deemed contraband.

Items allowed to be stored in entryway lockers include:

- Cell Phone / Cell Phone Charger
- Open cigarette boxes

- Matches, lighters
- Open cans of chewing tobacco

## **CELL PHONES**

One (1) unlocked cell phone is allowed per resident. All cell phones are subject to search at any time by staff and any image determined to be inappropriate will be considered contraband. You shall provide staff with the code to unlock the phone.

**RCF residents are required to sign and abide by a cell phone contract.**

- You must place your cell phone in your entryway locker immediately upon entering the facility. Cell phones are not allowed in any other part of the facility.
- Cell phones cannot be stored in offender vehicles.
- Cell phones must be turned off prior to entering the facility.
- You will not be allowed to access your cell phone or entryway locker until the next time you leave the facility.
- Cell phones will not be allowed to be used during recreational times.
- Cell phones may only be charged while stored in your entryway locker.

**Any violation of the cell phone rules will result in your cell phone being confiscated and your locker privileges being revoked.**

## **MOTOR VEHICLE OPERATION**

Driving is a privilege that can be denied, restricted or revoked at any time.

You must obtain permission from the Division Manager/Designee prior to purchasing or operating any motor vehicle. You shall have the Owing/Operating a Motor Vehicle Agreement completed and approved by the Division Manager/Designee prior to operating the vehicle.

### **Permission to Own and/or Operate a Motor Vehicle is based upon:**

- Confirmation of a valid Iowa driver's license
- Confirmation of liability insurance coverage
- Confirmation of vehicle license and registration
- Confirmation of vehicle ownership or permission from the owner
- Demonstration of responsible behavior
- *Operating While Intoxicated Continuum* offenders are required to have a work permit with written Division Manager/Designee approval prior to operating any motor vehicle, including but not limited to scooters and bicycles (WR/OWI-11).

### **After You Receive Permission to Drive**

- You may only operate motor vehicles to and from approved destinations.
- You may only transport other offenders for employment purposes (same location/same time) or treatment with Division Manager/Designee permission.
- Offenders on Field Supervision shall not transport RCF/RTC offenders unless prior Probation/Parole Officer approval is received.
- The authorized parking area is the lot at the corner of 9<sup>th</sup> Avenue and 10<sup>th</sup> Street, which is the lot between the RCF and RTC.
- Vehicles must remain locked at all times and keys must be turned into the control desk. (The Department is not responsible for offender vehicles or items damaged, lost, stolen or removed from the vehicles).
- Unemployed offenders may be permitted to operate motor vehicles to seek employment.

Vehicles are randomly inspected for contraband.

## **Riding in a Vehicle Operated by Someone Else**

You must have an approved Transportation Agreement on file for each person that will transport you during your stay. Being in a vehicle without an approved Transportation Agreement is a Formal Rule violation.

## **BIKES**

Bikes are the personal property of offenders and must be secured with a tamperproof padlock while on facility property. Bikes or bike parts determined to be refuse (garbage) by management will be immediately removed from the bike rack and disposed of. Bikes that are stolen or damaged are not the Department's responsibility.

## **EMPLOYMENT**

Pursuant to **Chapter 904, Section 901, of the Code of Iowa**, offenders are expected to secure and maintain gainful full-time employment and/or an educational program while housed at the facility. Employment is a critical factor in the success of an offender completing the residential program. Resources are available in the community for assessment and enhancement of job-readiness. Full-time employment is defined as thirty-two (32) hours per week.

### **Job Seeking Form, Rules and Requirements**

Job seeking is Monday through Friday, 8:00 a.m. to noon and 1:00 p.m. to 5:00 p.m. Saturday and Sunday job seeking activities must be approved by staff in advance. Unemployed offenders are expected to job seek.

- Complete a job seeking form indicating the locations you will job seek. The form must be completed by you and then approved by staff.
- You shall be dressed appropriately for job seeking (no pajamas, see-through, dirty, torn or tattered clothing).
- You are required to fill out applications at the place of employment you are applying at (cannot bring them back to the facility).
- Male and female residents are not allowed to job seek together.
- Advanced approval from your PPO is required to job seek if you have full-time employment AND to job seek in Omaha.
- You may only apply at the same place of employment once every two months.
- You are not allowed to apply in-person at employers that only accept online applications. A list of online-only employers is available at the Control Desk.
- Only two (2) residents at a time from each facility (a total of four) are allowed to check out to Iowa Works. Residents are only allowed to check out to Iowa Works a maximum of two (2) times per week.
- Upon return from job seeking, the job seeking form must be returned to staff containing all required information.

### **Job Verification Form / Review and Approval**

When employment is secured, you shall complete a Job Verification Form and give it to staff for review and approval. Staff can get you a temporary ID to help you get a permanent ID and then Social Security Card.

Staff shall verify all information relevant to the job prior to approving the employment, to include:

- Type of employment
  - No "cash jobs"
  - No bartending, massage parlors or "head shops"
  - Convicted sex offenders who have violated children may not work in contact with children
  - Convicted sex offenders cannot work in adult movie theaters or adult bookstores
  - Those convicted of OWI (current offense) cannot drive motor vehicles on jobs or work where alcoholic beverages are served (except restaurants)
  - Convicted embezzlers cannot handle large sums of money
  - Contact information for supervisor and human resources
- Work schedule

- Exact job location(s) (within 50 miles of the facility)
- Workman’s compensation insurance must be provided
- Compensation details (all pay must be turned in to staff)
  - Rate of pay – ensure it is at least minimum wage
  - Pay method and schedule
  - No cash advances

**Work Day / Paid Status Only**

You shall be signed out to a specific location or otherwise keep staff informed of your job site. You are responsible for getting to and from employment; staff do not transport.

**All employment hours are required to be in paid status.**

- No unpaid employment hours will be permitted.
- Loitering at your place of employment in unpaid status is not permitted.

You are not permitted to check out of the facility for employment purposes in excess of sixteen (16) hours per day (in a twenty-four (24) hour period from the time of sign-out), including travel time to and from work. Residents are required to be in the facility for a minimum of eight (8) hours before you can sign out for employment again. Exceptions to this rule can be made in advance by your Probation/Parole Officer.

**Missing Work Due to Illness**

If you do not go to work due to illness, it is your responsibility to notify your employer. You must stay in your room while you are sick. If you go to the Emergency Room, upon your return, you will remain in your room for a period of 24 hours unless you are approved to attend your employment or a treatment obligation.

Furlough privileges shall not interfere with job responsibilities and offenders who are unable to work because of illness shall not receive furlough privileges for those days they are absent from work, except to obtain medical services or to meet other program objectives.

**Change in Job Status**

Changes in job status are to have prior approval from staff. You may not quit a job without providing proper notice and having a different job already approved by staff.

**Temporary Employment / Agencies:**

Temporary agencies may be accessed earlier than 8:00 a.m. Prior to being allowed to check out of the facility for temporary employment, the temporary agency you are working for is required to contact the Control Desk to verify they have a job for you that day. If you choose not to accept employment offered (i.e. temp job) you may face progressive discipline.

Omaha @ Work	5015 Dodge St., Suite 100, Omaha	(402) 731-8300
Labor Systems	3220 South 24 <sup>th</sup> St Omaha	(712) 322-5100
Uptown Staffing	409 S. 8 <sup>th</sup> St., Council Bluffs	(712) 329-0900
Ascend Staffing	1824 2 <sup>nd</sup> Avenue Council Bluffs	(712) 256-5458
Express Staffing	1720 N 16 <sup>th</sup> St Suite H Council Bluffs	(712) 256-6970

**RELIGIOUS SERVICES**

Offenders in good standing shall be permitted one (1) religious furlough per week for up to three (3) hours (including travel time) to attend religious services of their choice. Religious services must be in Council Bluffs, Iowa. Attendance shall be within established curfew hours. Offenders on restricted status may utilize videotaped, audiotaped or written religious materials as a substitution for attending services off the facility grounds.

## VISITATION

**Visiting Day and Hours:** Wednesday 1:00 p.m. – 2:00 p.m. and 7:00 p.m. – 8:00 p.m.

### Visitor Application Process

A Visit Request Sheet is to be completed for anyone you want to visit you at the facility. You can have up to five (5) individuals listed – immediate family and significant others only. Your assigned PPO will review each proposed Visit Request Sheet and determine if each individual is approved or denied.

- Visitors currently on probation/parole supervision may not be allowed visitation privileges.
- In order to visit, juveniles must be accompanied by a parent or an adult that has been approved on the visitors list.

**No one can visit until they have been approved by your PPO.**

### Processing Visitors In To the Facility

Upon arrival at the facility, visitors shall immediately go to the Control Desk and do the following:

- Present staff with a valid, government-issued picture ID
- Identify the offender to be visited
- Sign the visitor sign-in sheet

Visitors must be dressed appropriately; no swimwear, short shorts/dresses or tight, see-through or revealing clothing allowed. All visitors and their belongings are subject to search. Those who furnish any offender with an intoxicant, controlled substance or other contraband may be subject to arrest.

### Visitors may not bring the following into the facility

- Handbags, purses, diaper bags, backpacks
- Cell phones
- Food / beverages

### Designated Visiting Area

The designated visiting area is as posted and will be enforced by staff. Visitors are never allowed in any offender living area, to include restrooms. All visits shall start and end inside the facility. **No outside visiting allowed at any time. Outside visiting will result in disciplinary action.** Staff will notify you that your visitor has arrived after they have completed the sign-in process.

Offenders not participating in visitation will be directed to their respective rooms or lounge until visitation is over.

### Visitation Rules

- Offenders and visitors are subject to the rules of the residential facility and must conduct themselves in a manner as to not compromise the safety, security or orderly running of the facility. If any visitor becomes troublesome or uncontrollable, they may be asked to leave.
- Visiting privileges may be terminated due to any of the following:
  - The apparent odor of alcohol or narcotics is detected.
  - The offender and visitor exchange any contraband.
  - Failure to supervise children when they interfere or disrupt other visits
- Vending machines may be used.
- Visitors may not use the payphones.
- The Division Manager or designee may reduce visiting times or days for cause.
- Visitors shall sign out at the Control Desk at the end of the visit.

## **Special Visits**

In order to have a special visit, you must complete the Special Visit Request Form and be approved by the Division Manager or designee.

## **PLEASURE FURLOUGHS**

Graduated furlough time may be granted as a reinforcement for positive behavior. Graduated furloughs are earned privileges and may be decreased or eliminated for inappropriate behavior. A furlough is defined as any temporary release from custody for work, treatment or other related leaves as approved by your supervising officer. You are not allowed to furlough with other residents of the RCF/RTC or Transitional House (regardless of gender).

**Week:** Tuesday at 8:00 a.m. through the following Tuesday at 8:00 a.m.

## **Eligibility**

- Fourteen (14) days after completing new resident orientation (**not** date of arrival).
- Rent must be current. If you owe back rent, you must be paying on it.
- Must have full-time employment.
- Cannot have a pending disciplinary report or be on disciplinary restriction.
- Must agree to a cell phone contract and install/download the Life 360 application on your smart phone. Your location must be enabled at all times while on furlough.

Receipts must be turned in to staff when you sign back in to the facility after designated furloughs. Failure to turn in a receipt may affect your ability to furlough in the future.

## **Address Approval**

All personal residences must be approved by your PPO prior to submitting a furlough request. The Furlough Address Approval form shall be submitted to your PPO for review and investigation. You can have up to two (2) personal residences for your furlough address. The PPO has ten (10) business days to approve or deny the address.

Residences will not be approved where firearms, alcohol or drugs are present, or which is inhabited by a person currently under correctional supervision.

## **Submitting a Furlough Request**

Furlough requests shall be submitted on the offender kiosk and must be completed at least twenty-four (24) hours in advance. Your furlough plan must include exact times and locations, which you will be required to follow.

*Example: Mom's house from 10am – 4pm  
Walmart from 4pm – 6 pm*

Staff will review furlough requests and either accept or reject the request. You can check the status of your pending request on the kiosk. There are instructions provided at each kiosk explaining the process of submitting the request.

- Hotel / Motel
  - You will not be approved to use funds from your Inmate Banking account to pay for a hotel or motel until you have earned a 24-hour furlough.
  - Female residents may only go to the AmericInn, located at 1000 Woodbury Avenue in Council Bluffs.
  - Male residents may furlough to a hotel other than the AmericInn, located at 1000 Woodbury Avenue in Council Bluffs.
  - You are required to indicate on your furlough sheet the name of the person the motel room is registered to. If a room is not available for your furlough, you will not be granted a motel pleasure furlough.

## **Furlough Order**

- 8 hours (two locations)
- 8 hours (two locations)
- 16 hours (to be used in 2 separate 8 hour furloughs) (two locations per 8 hours)
- 16 hours (to be used in 2 separate 8 hour furloughs) (two locations per 8 hours)
- 24 hours (overnight) (4 locations in 24 hours during curfew hours)
- 24 hours (overnight) (4 locations in 24 hours during curfew hours)
- 48 hours (overnight) (6 locations in 48 hours during curfew hours)

**\*\* Employment and treatment do NOT count as a location during furlough \*\***

## **Regulations**

- You are required to have your device's location permissions "on" for the Life 360 app to work. Prior to signing out, staff will verify your location sharing is working correctly. Turning off your location is a violation of facility rules and you will be required to return to the facility immediately.
- Furloughs start and end at the facility.
- You may be allowed to furlough outside of Council Bluffs as approved by the Division Manager or designee.
- Furloughs must be taken in the Fourth Judicial District in Iowa.
- You must be at your furlough address by 10:00 p.m. Curfew hours are from 10:00 p.m. to 6:00 a.m.
- You are required to follow the furlough plan that was approved by staff, to include locations and times. You must notify the control desk of any emergency or deviation from your furlough plan.
- You will be required to return to the facility if you receive a disciplinary report while on pleasure furlough.
- Failure to follow furlough regulations will result in starting the graduated furlough process over.

## **Medical Furlough Regulations**

Residents with a communicable disease or medical condition confirmed by a medical doctor may be placed on medical furlough. Residents must be cleared by a medical doctor prior to being allowed to return to the facility. Pregnant residents may be considered for medical furlough.

## **PASSES**

Receipts must be turned in to staff when you sign back in to the facility from passes. Failure to turn in a receipt may affect future passes.

**You may required to download the Life 360 application and have your location enabled at all times while on all passes.**

## **Gas Station**

You are allowed to check out to the gas station at 503 9<sup>th</sup> Avenue in Council Bluffs, Iowa once a week, Tuesday through Monday for a period of thirty (30) minutes.

## **Check Cashing**

If you receive a department-issued refund check, you may be allowed to cash your check at a bank in Council Bluffs. Accommodations may be made if you are unable to cash your check during banking hours.

## **Health Club**

### **Eligibility**

- Rent must be current.
- Not on disciplinary restriction.
- Must have full-time employment.

- Must show proof of a valid health club membership prior to signing out.

Regulations

- You may be allowed to check out to a Council Bluffs health club up to two (2) times per week for two (2) hours on each occasion. The YMCA is not allowed.
- You are required to call the facility when you arrive and when you leave to return to the facility.

**Religious**

You may be authorized one (1) pass for religious purposes per week not to exceed three (3) hours and must be taken in Council Bluffs. This pass may be used any day of the week.

**Restaurant**

Eligibility

- Rent must be current.
- Not on disciplinary restriction.
- Must have full-time employment.

Regulations

- You may be authorized one (1) restaurant furlough per week, not to exceed two (2) hours.
- The restaurant must be located in Council Bluffs.
- You cannot go with other RCF/RTC/Transitional House residents (same location at the same time).
- Restaurant passes must be requested twenty-four (24) hours in advance.
- Restaurant and shopping passes may be combined one time per month for a total of four (4) hours.

**Grooming (Hair / Nails)**

Eligibility

- Not on disciplinary restriction.

Regulations

- You may be authorized no more than two (2) hours per calendar month.
- You must remain in Council Bluffs, unless approved by the Division Manager/Designee.
- You are required to call the facility when you arrive and when you leave to return to the facility.
- You cannot go with other RCF/RTC/Transitional House residents (same location at the same time).
- Grooming passes must be requested twenty-four (24) hours in advance.
- Grooming and shopping passes may be combined one time per month for a total of four (4) hours.

**Shopping**

Eligibility

- Not on disciplinary restriction.

Regulations

- You are authorized one (1) shopping pass every two (2) weeks for no more than two (2) hours.
- Shopping passes shall be authorized for specific needs, i.e., clothing, work requirements, hygiene items, personal items, etc.
- You must identify the store(s) where you plan to shop. At no time shall you be authorized to “window shop/hang out”.
- You are required to call the facility when you arrive and when you leave to return to the facility.
- You must remain in Council Bluffs, unless approved by the Division Manager/Designee.



- You cannot go with other RCF/RTC/Transitional House residents (same location at the same time).
- Shopping passes must be requested at least twenty-four (24) hours in advance.
- Shopping and grooming passes may be combined one time per month for a total of four (4) hours.

### **PRIVILEGED COMMUNICATION**

You have access to communication with legal counsel, clergy, the judiciary and the office of the State Ombudsman. These communications will be treated as privileged and are not subject to censorship, but shall be at the convenience of the facility operation. When you wish to speak by telephone with the above individuals, you must, under normal circumstances, use the pay telephone.

The following situations will warrant exceptions to policies described in the above paragraph:

1. If you are without money and there is sufficient urgency.
2. Incoming calls from any of the four parties may be taken by you on the office telephone.

In addition to the grievance, appeals and privileged communication process, you may contact the State Ombudsman at anytime:

Iowa Citizen's Aide Office, Ola Babcock Miller Building, 1112 East Grand Avenue, Des Moines, Iowa 50319-0231  
1-(515) 281-3592 or 1-(888) 426-6283

Telephone privileges – Payphones are available, without censorship, from 6:00 a.m. to 10:30 p.m. daily. Day room closes at 10pm; facility closes at 10:30pm, lights out by 11pm.

RCF and RTC Male Offender Voicemail: (712) 828-8820      RCF Female Offender Voicemail: (712) 355-5008

### **Courts/Law Library**

You may have access to the appropriate Court to address legal matters. The following is the address and phone number of the Clerks of Court in the Fourth Judicial District:

Audubon County Clerk of Court Audubon, Iowa 50025 (712) 563-4275	Montgomery County Clerk of Court Red Oak, Iowa 51566 (712) 623-2986	Cass County Clerk of Court Atlantic, Iowa 50022 (712) 243-2105
Page County Clerk of Court Clarinda, Iowa 51632 (712) 542-3214	Pottawattamie County Clerk of Court Council Bluffs, IA 51502 (712) 328-5604	Fremont County Clerk of Court Sidney, Iowa 51652 (712) 374-2232
Harrison County Clerk of Court Logan, Iowa 51546 (712) 644-2665	Shelby County Clerk of Court Harlan, Iowa 51537 (712) 755-2667	Mills County Clerk of Court Glenwood, Iowa 51534 (712) 527-4880

Offenders requiring the use of a Law Library must contact the State Law Library, State Capitol Building, Room 200, Des Moines, Iowa, 50319. Phone - 1-800-248-4483. Fax - 1-515-281-5405.

### **CORRESPONDENCE**

You have the opportunity for correspondence with family, friends and community resources.

You have the right to send and receive uncensored mail. However, the facility retains the right to inspect all incoming mail for the presence of contraband, by having you open it in front of staff. You are required to obtain permission from your PPO to correspond with other offenders who are currently incarcerated. It is your responsibility to inform your family and friends of these correspondence rules.

If contraband items which are not illegal to possess under the law are found in the mail, the mail will be rejected and you shall be notified with the option to return to sender or destroy. Illegal items/contraband will be reported to law enforcement. The facility will forward incoming mail back to the sender when the offender is no longer a resident of the facility. The mail will be stamped "No Longer at this Address. Return to Sender."

Residents are required to obtain their Facility and U.S. Mail at the Control Desk on a daily basis.

## GRIEVANCES

A regular grievance is a formal, written complaint, utilizing the established procedures, filed by an offender. Grievances must clearly indicate the action or condition with which you disagree. All regular grievances shall be submitted in writing, within three (3) working days of knowledge of the incident for which the grievance is based. All grievances must be signed and dated by the offenders submitting the grievance.

Grievances involving allegations of sexual abuse, sexual harassment, retaliation or staff neglect may be reported to staff verbally, anonymously or to the Ombudsman's Office. There is no time limit for reporting sexual abuse, sexual harassment, retaliation or staff neglect. Management will provide an initial response to emergency grievances within forty-eight (48) hours, and shall issue a final department decision within five (5) calendar days.

Third parties, including fellow offenders, staff members, family members, attorneys and outside advocates shall be permitted to assist offenders in filing requests for administrative remedies relating to allegations of sexual abuse, and shall also be permitted to file such requests on behalf of offenders. (See PREA section)

**\*\*\* Formal Reports, Informal Reports and sanctions are not grievable.**

## LEISURE ACTIVITIES

RFC: Basketball, horse shoes, T.V., board/table/card games, reading

RTC: Basketball, T.V., board/table/card games, reading

- Table and card games are allowed to be played only in the multipurpose room upon receiving staff permission. Table and card game materials shall be stored in the multipurpose room or control desk only. These materials are not allowed in resident rooms.
- Only movies containing a PG-13 rating or below are allowed in the facilities.

**Community Agency Referrals:** Available, at each offender's own expense:

1. Medical Services: You are responsible for your own medical expenses.
  - a. CHI Mercy Hospital, Council Bluffs, Iowa (712) 328-5000
  - b. Jennie Edmundson Hospital, Council Bluffs, Iowa (712) 396-6000
  - c. All Care Health Center, Council Bluffs, Iowa (712) 325-1990
  - d. Planned Parenthood, Council Bluffs, Iowa (712) 322-6650
  - e. Visiting Nurses Association, Council Bluffs, Iowa (712) 328-3990
2. Mental Health Services / Counseling / Advocacy
  - a. Alegent Health Psychiatric Associates, Council Bluffs, Iowa (712) 328-2609
  - b. All Care Health Center, Council Bluffs, Iowa (712) 325-1990
  - c. Catholic Charities, Council Bluffs, Iowa (712) 328-3086
  - d. Family Access Center, Council Bluffs, Iowa (712) 328-3700
  - e. Heartland Family Service, Council Bluffs, Iowa (712) 322-1407
  - f. Horizon Therapy Group, Council Bluffs, Iowa (712) 256-7511
  - g. Mid-Iowa Family Therapy Clinic, Council Bluffs, Iowa (712) 325-1136

3. Substance Abuse Treatment
  - a. Alegent Health Psychiatric Associates, Council Bluffs, Iowa (712) 328-2609
  - b. Family Access Center, Council Bluffs, Iowa (712) 328-3700
  - c. Heartland Family Service (OWI Program), Council Bluffs, Iowa (712) 322-1407
  - d. Local and virtual AA/NA meetings
  
4. Educational Programs / GED
  - a. Iowa Western Community College, Council Bluffs, Iowa (712) 325-3200
  - b. Adult Learning Center, Council Bluffs, Iowa (712) 325-3266
  - c. Vocational Rehabilitation Center, Council Bluffs, Iowa (712) 328-3821
  
5. Vocational Evaluation and Training
  - a. Iowa Works, Council Bluffs, Iowa (712) 242-2100
  - b. Vocational Rehabilitation Center, Council Bluffs, Iowa (712) 328-3821

### **DISCIPLINE PROCEDURES**

Violations of rules and procedures are divided into two categories → Informal and Formal

- **Informal infractions:** *No formal hearing is held for minor violations.*
- **Formal violations:** *A formal disciplinary hearing shall be held. Upon being notified that you have received a major violation, you are placed on facility restriction until further notice.*

Following the writing of a Formal disciplinary report, an investigation will be conducted by a staff member. Witnesses or their statements may be used at the investigation or hearing stage. If witness testimony would be repetitive or inappropriately hinder the investigatory or hearing process, the investigator or hearing officers may limit the number of witnesses interviewed.

*Failure to name witnesses at the investigation stage will result in no further opportunity for such witnesses except at the discretion of the Hearing Committee.*

Once the investigation is completed, staff will conduct a Disciplinary Hearing within seven (7) working days of the offender's receipt of a written notice of the alleged rule violation. When a disciplinary report is written, offenders will be given twenty-four (24) hours-notice for their appearance at their hearing. When the hearing is continued, the offender shall be advised, in writing, of the reason(s) for the continuance within the seven (7) working days limitation. At the hearing, offenders have no right to legal counsel nor do they have the right to confront or cross-examine witnesses. Witnesses' appearance at the hearing can be limited or disallowed entirely, for cause.

Following the conclusion of the Disciplinary Hearing, offenders will be given written notice of the hearing findings and any sanctions imposed. The sanction(s) imposed by the Disciplinary Hearing Committee shall be imposed immediately and not deferred as a part of the appeal process.

### **DISCIPLINARY SANCTIONS**

The disciplinary committee may impose any of the following sanctions, including a combination of any of the sanctions:

- **Graduated sanctions will be used for every positive UA/BA or admission of usage, as noted below:**
  - 1<sup>st</sup> violation: Seven (7) days facility restriction
  - 2<sup>nd</sup> violation: Fourteen (14) days facility restriction
  - 3<sup>rd</sup> violation: Thirty (30) days facility restriction

The facility restriction will start from the date of the positive UA/BA or from the date of admission of usage.

These sanctions may not be run consecutively.

Administrative / Recommend Revocation	Phone Restriction - Days
Community Service / Extra Detail	Privilege Level Reduction
Early Room Curfew	Recreation Modification
Extra Duty - Days	Room Restriction - Days
Extra Duty - Hours	Room Restriction - Hours
Facility Restriction - Days	Special Condition
Facility Restriction - Hours	Warning / Reprimand
Furlough / Pass Restriction	Writing Assignment

You are reminded that continued placement is based on the ability to follow the program rules. When your overall behavior warrants a review of your placement, your facility restriction shall be extended until final disposition is reached.

Disciplinary sanctions are at the discretion of the disciplinary hearing committee and shall begin upon completion of the hearing. Room and facility restriction may run concurrent.

## **DISCIPLINARY RESTRICTION GUIDELINES**

### **ROOM RESTRICTION**

**While on room restriction, you may:**

- go to work
- job seek
- attend treatment (includes case plan related community treatment providers)
- eat during posted meal times
- seek medical attention
- participate in Wednesday visitation
- attend religious service (in-house only)
- cash personal spending check
- with staff permission → hygiene related activities (shower, use the restroom)

**While on room restriction, you may NOT:**

- go on passes
- go on pleasure furloughs
- go outside
- use the pay phones
- do extra duties
- watch television
- go to the gas station
- go to AA/NA meetings
- outdoor rec time / smoke

### **FACILITY RESTRICTION**

**While on facility restriction, you may:**

- go outside
- go to work
- job seek
- attend treatment (includes case plan related activities such as community treatment providers)
- seek medical attention
- participate in Wednesday visitation
- attend religious service (in-house only)
- cash personal spending check
- outdoor rec time / smoke

**While on facility restriction, you may NOT:**

- go on passes
- go on pleasure furloughs
- go to the gas station
- go to AA/NA meetings

## **RULE VIOLATIONS**

You shall obey all laws, ordinances, applicable institutional rules, house rules and the following facility regulations:

1. **ILLEGAL BEHAVIOR:**

*When an offender plans, participates, assists, condones or encourages others to violate a local state or federal law, whether the offense is committed inside or outside the residential facility and whether the offense actually occurs.*

2. **VERBAL ABUSE:**

*When the offender subjects another person to abusive or defamatory, insolent or disrespectful language or remarks, whether written or oral or abusive, defamatory, insolent or disrespectful gestures.*

3. **THREATS / INTIMIDATION:**

*When the offender communicates a determination or intent to injure another person or to commit a crime of violence or an unlawful act dangerous to human life, and the probable consequence of such threat or threats (whether or not such consequence, in fact, occurs) is:*

- a. *To place another person in fear of bodily injury; or*
- b. *To cause damage to property; or*
- c. *To take place in the future after released from confinement.*

4. **DISOBEYING A LAWFUL ORDER OR DIRECTIVE:**

*When an offender refuses to obey an order (written or verbal) given by a person in authority, which is reasonable in nature, or attempts to circumvent established procedures.*

5. **FALSE STATEMENTS:**

*When the offender knowingly makes a false statement whether or not under oath or affirmation, including, but not limited to, dishonesty, deception, failure to disclose, cheating, etc.*

6. **UNAUTHORIZED POSSESSION / EXCHANGE:**

*When an offender has in possession on their person, in the offender's living area, locker, or immediate place of work or other program assignment, or receives from, or gives to another offender, any item delineated as unauthorized or contraband by District policy.*

7. **POSSESSION OF DANGEROUS CONTRABAND:**

*When the offender possesses, used, or has under their control or custody, an item defined as dangerous contraband by District policy. Contraband shall include, but not be limited to the following:*

- A. *Alcohol, any alcoholic beverage and alcohol-based products*
- B. *Drugs, drug paraphernalia, K2, bath salts, synthetic substances and unauthorized medications*
- C. *Unauthorized keys*
- D. *Firearms, knives or other weapons*
- E. *Incense / candles*
- F. *Hypodermic needles or syringes*
- G. *Eyedroppers*
- H. *Unauthorized office supplies, lottery tickets, scratch tickets, Powerball*
- I. *Vinegar*
- J. *All electronic cigarette parts and juices, tobacco products and imitation tobacco products*
- K. *Mirrors*
- L. *String, rope, wire, etc.*
- M. *Beepers and cell phones*
- N. *Handheld video games, T.V., musical instruments*
- O. *Unauthorized food / beverage products*
- P. *Unauthorized gambling paraphernalia (poker chips, dice, etc.)*
- Q. *Material which threatens, attempts to blackmail or is written in code*
- R. *Any material or substance which could be potentially harmful or threatening to the security of the*

- offenders or staff*
- S. *Space heaters*
- T. *Nail polish, polish remover, aerosol containers, mouth wash, hydrogen peroxide and all flammable materials*
- U. *Cameras or any electronic devices capable of taking photos.*
- V. *Pornographic material*
- W. *Extension cords*
- X. *Tattoo paraphernalia to include tattoo gun, needles, etc.*
- Y. *Flowers, balloons, glass vases, stuffed animals / dolls*
- Z. *Hair clippers and beard trimmers*

8. **POSSESSION / USE OF DRUGS OR INTOXICANTS:**

*When an offender is in possession or has been in possession of any unauthorized drug, synthetic drug or intoxicant. This includes paraphernalia that is used in relationship to drug/intoxicant use, sale, positive urinalysis, or positive blood test. The offender must provide a testable sample within two (2) hours of the request. Failure to do so may constitute a violation of this rule. An offender may also be found to be in possession of a drug or intoxicant for which there is no readily available urinalysis testing if the offender displays symptoms or actions that are consistent with intoxication and/or fails any field sobriety tests administered by the residential staff or law enforcement personnel.*

9. **POSSESSION / USE OF ALCOHOL:**

*When an offender is in possession of, or has consumed alcohol or any product containing alcohol. This includes results from any manner of testing including, but not limited to, a positive breath, alco-sensor test or admission of use. Refusal to submit to a test for alcohol use shall constitute a violation of this rule. Offenders are not allowed to enter establishments where alcohol is served without prior staff permission.*

10. **ABUSE OF MEDICATION:**

*When an offender fails to follow the prescription or package directions of any medications. An offender shall also be considered in violation of this rule when they give their medication to another person. Medication shall be stored in its original container.*

11. **ESCAPE:**

*When an offender is absent from the residential facility without proper authorization for over two (2) hours, or there is probable cause to believe the offender has taken flight or is involved in a criminal offense.*

12. **OUT OF PLACE OF ASSIGNMENT:**

*When an offender is not at their designated place of assignment (residential facility, work place, treatment program, furlough, or other authorized leave) and/or fails to use the most direct route or method of transportation. Offenders are responsible for promptly notifying the residential facility staff of any proposed changes in their work schedule or furlough plan and must receive staff approval of all changes.*

13. **FAILING TO SECURE / MAINTAIN EMPLOYMENT:**

*When an offender fails to actively seek, secure and maintain full time employment as approved by staff. When an offender jeopardizes employment, quits without staff approval, or is terminated from their job.*

14. **SEXUAL MISCONDUCT:**

*When an offender proposes or engages in sexual contact with another offender at any time; or any other person on residential facility property (or premises) or engages in sexual contact at any location with a person who is*

also a resident of a correctional residential facility. Indecent exposure also constitutes sexual misconduct. This includes, but is not limited to, offensive exposure of the genitals or pubic area in a manner to be seen by another person; gesture of a sexual nature to cause embarrassment or to be offensive to another person. Sexual misconduct may be written as well as verbal communication. Offenders are not allowed to have sexual contact with each other while participating in the program. This includes while on pass or furlough.

15. **UNAUTHORIZED USE OF A MOTOR VEHICLE:**

*When an offender uses a motor vehicle as a means of transportation, whether as a driver or passenger, without staff permission.*

16. **UNAUTHORIZED POSSESSION OF MONEY, CASHING PAYCHECK, UNAUTHORIZED ACCOUNTS, DEBIT CARDS OR PURCHASES:**

*When an offender cashes a paycheck, fails to turn in all monies to staff, obtains a checking account, savings account, credit card, charge account, debit card, pay in advance or any payroll deductions for personal use without staff approval or control. Offenders are also in violation when they make purchases, or incur debts, without staff approval. All money shall be turned into residential facility staff and all expenditures must be done through the residential facility budgeting process and with prior staff approval.*

17. **THEFT:**

*When an offender takes possession or control of the property of another, or property in the possession of another, with the intent to deprive the rightful owner of the use or benefit of the property.*

18. **BARTERING / SELLING GOODS:**

*When an offender barter, loans, gives, accepts, sells or buys thing of value, enters into financial agreements or contracts, engages in a business including, but not limited to, clothing, personal items, furnishings, etc. transfers or attempts to transfer or accepts transfer of funds from one offender to another offender, or agrees to perform or receive services or gifts, for anything of value without staff approval.*

19. **GAMBLING, DEBTS, ETC.:**

*When an offender plays any game for things of value or wagers anything on the outcome of an event or game; or incurs an unauthorized debt (i.e., cash advances, work debts, etc.).*

20. **SAFETY / SANITATION VIOLATION:**

*When an offender engages in any practice contrary to written or verbal safety instructions; or is unsanitary/untidy in their personal hygiene, living quarters, common areas of the residential facility, fails to satisfactorily clean the facility as assigned or smokes in an unauthorized area and/or disposes trash or cigarette butts in other than designated receptacles.*

21. **FAILURE TO COMPLY WITH SPECIAL CONDITIONS OR PARTICIPATE IN TREATMENT:**

*When an offender fails to be involved in a required educational or treatment program, which shall include failure to follow through with any special condition imposed by staff or to fully participate in treatment or educational activities. This includes failure to comply with a case plan.*

22. **TAMPERING WITH LOCKS OR SECURITY ITEMS:**

*When an offender locks, unlocks or alters a locking device, fire alarm system, or security item without authorization. This includes any unauthorized possession of a key or key pattern and electronic monitoring devices.*

23. **DAMAGE TO PROPERTY:**

*When an offender intentionally or negligently causes damage to property of another person, or of the state, such as tampering with electronic, mechanical, or plumbing devices or fixtures. This also includes damage to property resulting from other misconduct (i.e., fighting, horseplay, theft, disruptive conduct, etc.) This includes destruction and/or damage to state property.*

24. **FIGHTING:**

*When an offender engages in a physical altercation including the exchange of blows, shoves, kicks, offensive physical contact or, if horse playing, the physical contact need not be in anger. This may result in the offender's arrest.*

25. **ASSAULT:**

*When an offender intentionally causes or threatens to cause injury to another person or applies any physical force or offensive substance (such as feces, urine, saliva, mucous, or any other item) against any person regardless of whether injury occurs, to include sexual assault. This may result in the offender's arrest.*

26. **VIOLATION OF A CONDITION OF LEAVE OR FURLOUGH:**

*When an offender fails to comply with any condition of a leave or furlough from the residential facility.*

27. **UNAUTHORIZED GROUP / GANG CONDUCT:**

*When an offender displays or promotes involvement in an unauthorized group/gang through any of the following means: writing, words, physical appearance, and hand signs, symbols, and photographs, possession of group/gang-related materials or association with others known to be affiliated with an unauthorized group/gang.*

28. **OBSTRUCTIVE / DISRUPTIVE CONDUCT:**

*When an offender interferes with staff duties, or conducts themselves in a manner that disrupts or interferes with the secure and orderly running of the residential facility.*

29. **HABITUAL MINOR OFFENDER:**

*When an offender is repeatedly found in violation of minor/medium violations. The number and types of offenses, and prescribed time frames may be reflected in District policy.*

30. **ATTEMPT OR COMPLICITY:**

*When an offender attempts to commit any of the listed offenses or is involved with others who are committing or attempting to commit any of the listed offenses.*

## **APPEALS**

An appeal is a written statement of disagreement with findings or procedures of a disciplinary action. (If the offender has waived or refuses to appear at hearing, appeal rights are lost). Sanctions given as a result of Informal Discipline or as a result of a disciplinary hearing must be completed immediately, even if you appeal the decision. Appeals must state what action is being appealed, the grounds for the appeal and remedial action requested. You are expected to file appeals in accordance with the following:

### **Filing Appeals:**

1. At the time of notification of the disciplinary action decision for a formal or informal report, you shall notify staff



of your desire to appeal or not appeal. Appeals from disciplinary reports must be submitted in writing to the Division Manager/Designee within twenty-four (24) hours of the disciplinary committee's decision. (Policy 527).

2. The appeal must include all reasons for the appeal and corrective action sought from the process. This appeal must be signed and dated by you and any person assisting in putting the document together. In the event the Division Manager/Residential Supervisor is on leave or not in the office during the time the appeal is submitted, the appeal will be continued until their return.
3. The Division Manager/Residential Supervisor shall convene an appeal hearing within five (5) working days and report back to the offender either their decision of upholding the original findings, modifying the original findings, or reversing the original findings. In the event the Division Manager is on leave or not in the office during this time frame, the appeal will be continued until their return.
4. If the offender disagrees with the findings as reported in Step #3, the offender may contact the Iowa Citizen's Aide Office / Ombudsman's Office within seven (7) working days (Ola Babcock Miller Building, 1112 East Grand Avenue, Des Moines, Iowa, 50319-0231), Phone: (515) 281-3592 or (888) 426-6283. The Iowa Citizen's Aide Office / Ombudsman's Office will not accept collect phone calls.
5. You may contact your PPO for questions regarding loss of good time.

# RCF EMERGENCY EVACUATION PLAN

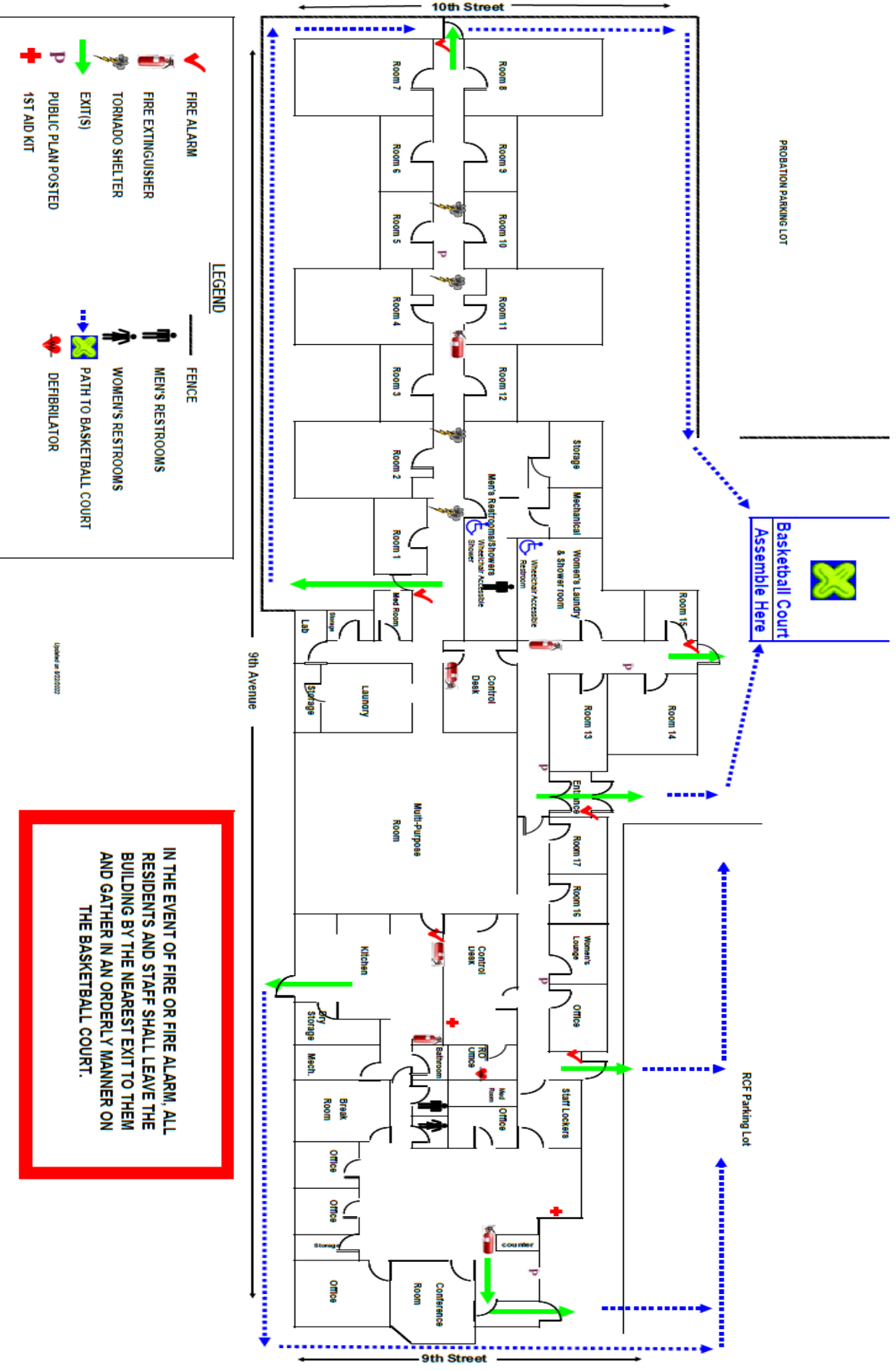

# RTC EMERGENCY EVACUATION PLAN

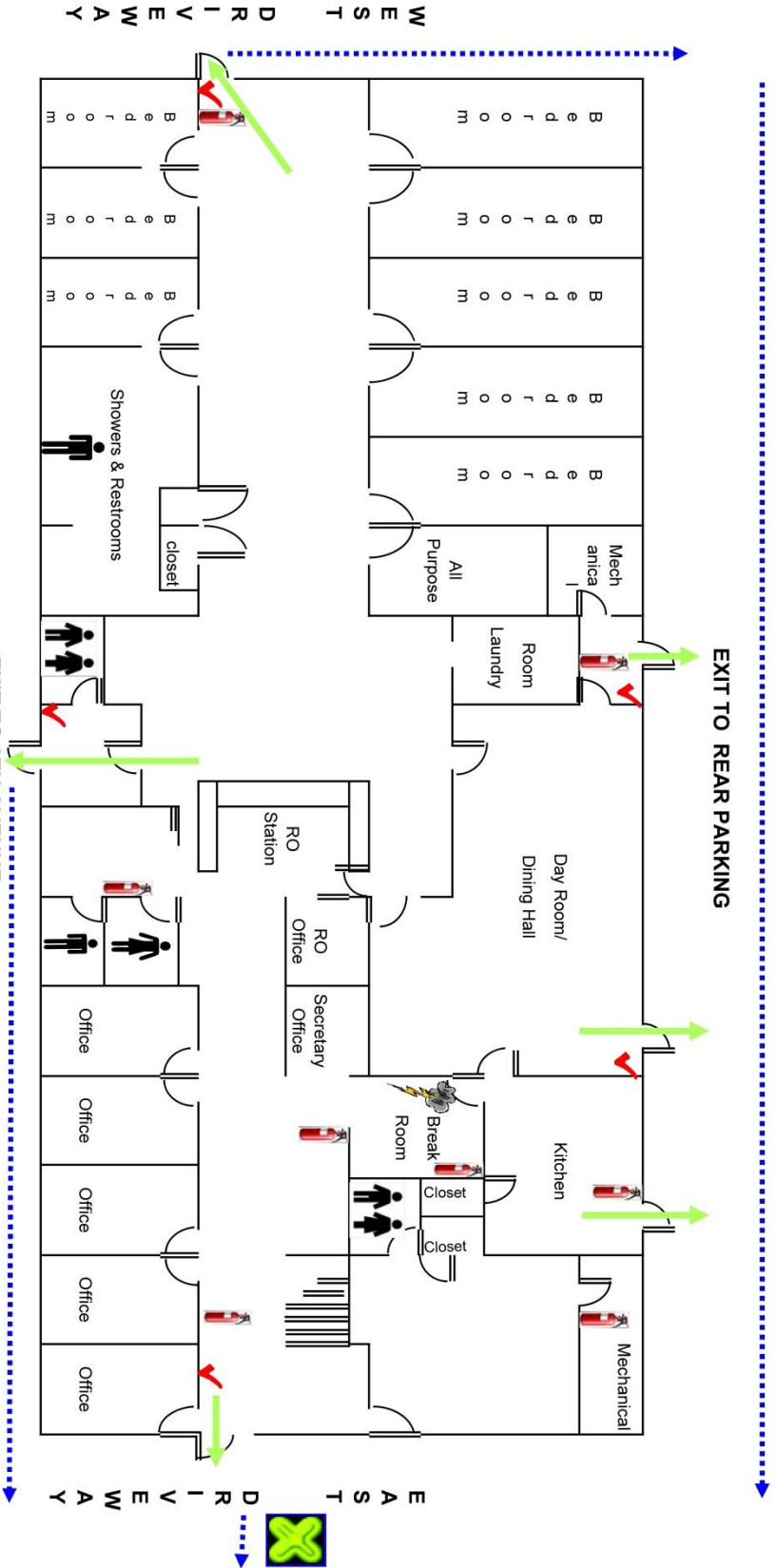

**LEGEND**

- FIRE ALARM
- FIRE EXTINGUISHER
- TORNADO SHELTER
- EXIT(S)
- WOMEN'S RESTROOMS
- MEN'S RESTROOMS
- PATH TO EAST SIDE LOT

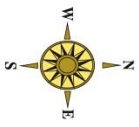

**IN THE EVENT OF FIRE OR FIRE ALARM, ALL RESIDENTS AND STAFF SHALL LEAVE THE BUILDING BY THE NEAREST EXIT TO THEM AND GATHER IN AN ORDERLY MANNER ON THE EAST SIDE VACANT LOT.**